

20. DNA can be extracted from a culture of white blood cells and precipitated using the following procedure:

1. Mix a culture of white blood cells with a detergent.
2. Add salt.
3. Add an enzyme.
4. Place in a water bath at 40 °C.
5. Filter the culture.
6. Gently pour ice-cold ethanol onto the filtrate.

i. Suggest why the cells do not need to be crushed before adding detergent.

..... [1]

ii. Explain why the detergent is used in step 1.

..... [1]

iii. Suggest the type of enzyme that should be used in step 3 and explain why.

..... [2]

21. A group of students tried to purify some DNA from leek cells using the following method. They decided that exact volumes were not necessary.

1. Grind a leek leaf to a fine pulp using a pestle and mortar.

2. Add salt and cold water and mix again for at least 10 s.

3. Add protease enzyme and mix again for at least 10 s.

4. Filter the liquid into a test tube and stand for at least 10 min.

5. Tilt the test tube and gently pour in ice-cold ethanol.

6. A white layer of DNA forms between the sample and the ethanol.

7. Extract the white layer carefully using a glass rod.

i. State the purpose of step 1.

.....  
.....

[1]

ii. Suggest why a protease enzyme added in step 3 is needed to purify DNA.

.....  
.....

[1]

iii. The students considered using pineapple juice as a source of protease enzyme.

Suggest why this would **not** be an appropriate source of protease when attempting to produce a pure sample of leek DNA.

-----  
-----

[1]

iv. State one important step that the students had left out of their method.

-----  
-----

[1]

v. Name the process described in step 6.

-----  
-----

[1]

**22.** A group of students attempted to extract and purify DNA from a plant in Upper End Meadow.

The students used the following steps:

1. Mix the plant sample with detergent.
2. Add salt.
3. Add protease enzyme.
4. Spool the DNA precipitate onto a glass rod.

Suggest whether this method would successfully extract and purify DNA. Justify your conclusion.

-----  
-----  
-----  
-----  
-----  
-----  
-----  
-----  
-----  
-----

[3]

23. A student tried to extract some DNA from a crushed banana at home. DNA dissolves in water but the student realised that they needed to add something to break open the nuclear envelope to release the DNA.

Suggest a suitable substance the student could use to release the DNA, **and** explain why it should work.

-----  
-----  
-----  
-----  
-----

[2]

24. A DNA molecule contains polynucleotide strands.

i. Individual nucleotides are joined together to make a polynucleotide strand.

What type of chemical reaction takes place when two nucleotides in a single polynucleotide strand are joined together?

-----

[1]

ii. Name the chemical released when the bond is formed between the two nucleotides.

-----

[1]

iii. A DNA molecule contains two polynucleotide chains.

Describe how these two chains are held together.

-----  
-----  
-----  
-----  
-----

[3]

25. Explain how the nucleotides in a DNA molecule are arranged as two polynucleotide strands.

.....

.....

.....

.....

.....

.....

.....

.....

[3]

26. The chromosomes carried by sperm are made of DNA.

The following passage about nucleic acids has four words missing. Choose the correct missing words from the list below and complete the passage by writing them in the gaps.

- |                  |                 |                   |                   |               |
|------------------|-----------------|-------------------|-------------------|---------------|
| <b>pentose</b>   | <b>nucleus</b>  | <b>adenosine</b>  | <b>hydrolysis</b> |               |
| <b>spiral</b>    | <b>polymers</b> | <b>nucleotide</b> | <b>fibres</b>     | <b>hexose</b> |
| <b>phosphate</b> | <b>strands</b>  | <b>base</b>       | <b>two</b>        |               |

Nucleic acids are made from ..... monomers.

Phosphodiester bonds form between the monomers. They consist of a ..... group between the ..... molecules, forming the 'backbone' of the molecule.

In DNA, hydrogen bonding between the two antiparallel ..... causes the characteristic double helix shape.

[4]

27. DNA is a biological molecule that varies between individuals.

Sections of DNA code for proteins.

Fig. 16.1 shows the structure of part of a DNA molecule.

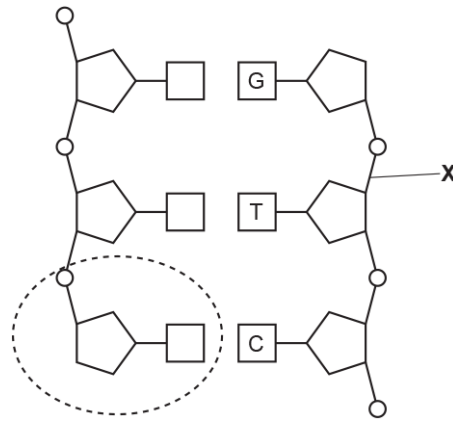

Fig. 16.1

i. The circled region shows one nucleotide.

Name the components of **this** nucleotide.

.....

.....

.....

[3]

ii. State the name of the bond labelled **X** and the type of reaction that forms this bond.

Name

.....

Type of reaction

.....

[2]

28. Fig. 24 shows a DNA nucleotide.

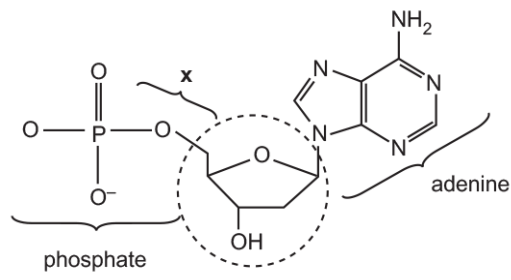

Fig. 24

Identify two similarities and two differences between the DNA nucleotide shown in Fig. 24 and a molecule of ATP.

Similarities

.....

.....

.....

.....

Differences

.....

.....

.....

29. DNA is arguably the most important molecule in the whole of biology.

When a cell divides an identical copy of its DNA is made in a process called DNA replication.

Explain how pairing of nitrogenous bases allows identical copies of DNA to be made.

.....

.....

.....

.....

.....

[3]

30. Fig. 21 shows a molecule of ADP.

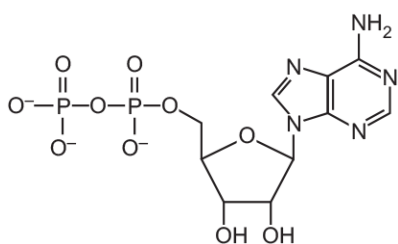

Fig. 21

i. On Fig. 21, draw a circle around the part of the ADP molecule that is a purine.

[1]

ii. State **two** differences between a molecule of ADP and a DNA nucleotide that contains adenine.

1

.....

.....

2

.....

.....

[2]



iii. ADP binds with an inorganic phosphate ( $P_i$ ) to make ATP.

Name this type of reaction.

-----  
[1]

31. Fig. 22 shows four nucleotides.

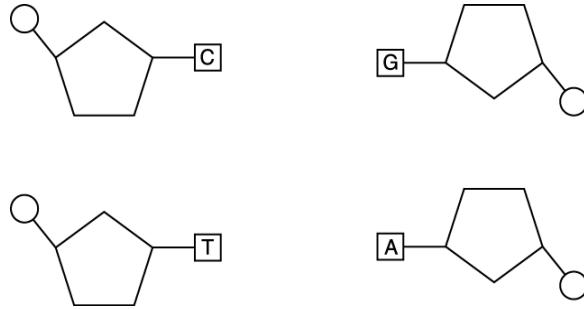

Fig. 22

On Fig. 22, draw and label the bonds holding the nucleotides together as part of a DNA molecule.

[2]

32. Fig. 16.1 shows the structure of ATP.

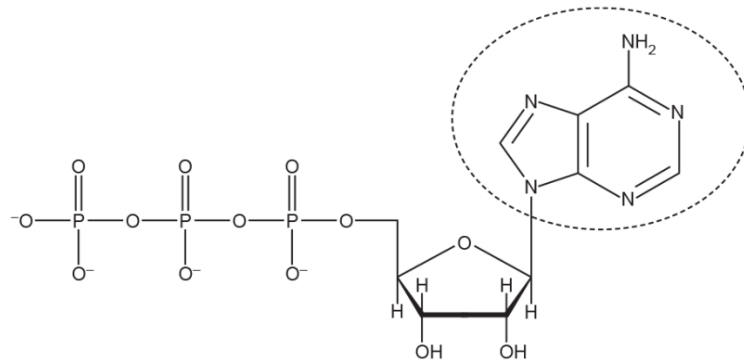

Fig. 16.1

i. Name the circled component in Fig. 16.1.

-----  
[1]

ii. Name the type of reaction that occurs when ATP is converted to ADP.

-----

[1]

- iii. A teacher told his students that the human body makes the equivalent of its own mass in ATP every day.

Explain why, at the end of the day, only a small proportion of the students' mass was ATP.

-----

-----

-----

-----

-----

[2]

33. Fig. 24 shows a DNA nucleotide.

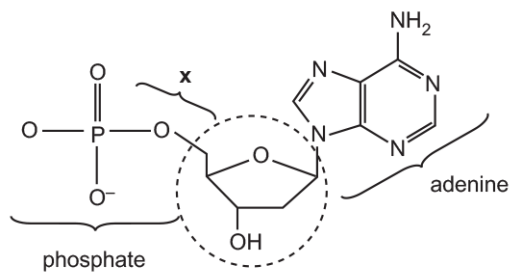

Fig. 24

- i. Name the circled component in Fig. 24.

-----

[1]

- ii. Name the bond labelled **x** in Fig. 24.

-----

[1]

## Nucleotides and Nucleic Acids

34. Even the smallest DNA molecules are very long.

- A kilobase (Kb) is a unit equivalent to 1000 base pairs of a DNA molecule.
- One Kb of double stranded DNA has a length of 0.34  $\mu\text{m}$ .

The DNA in the nucleus of a cell from a fruit fly (*Drosophila*) is 5.6 cm long.

- i. Calculate the number of Kb in the DNA of the fruit fly.  
Show your working. Give your answer to the nearest whole number.

Answer = ..... Kb

[2]

- ii. The DNA of the fruit fly was analysed and 22% of the bases were adenine.

What % of the bases were guanine? Show your working.

Answer = ..... %

[2]

35. DNA replication and transcription are two processes that occur in the nucleus of eukaryotic cells.

\* Compare DNA replication and transcription by describing the similarities and differences between the two processes.

---

---

---

---

---

---

---

---

---

---

---

---

---

---

---

---

---

---

---

---

---

---

---

---

---

---

---

---

---

---

36.

- i. The human genome contains  $3.0 \times 10^9$  nucleotides. The replication of DNA takes six hours in some cells.

One eukaryotic enzyme complex can replicate DNA at a rate of 50 nucleotides added per second on each complementary strand.

Calculate the number of eukaryotic enzyme complexes needed to replicate the DNA in the human genome in six hours.

Give your answer in standard form.

number of enzyme complexes = ..... [3]

- ii. Name **two** enzymes involved in DNA replication.

1

.....

2

.....

[2]

- iii. Explain why enzymes are essential to all organisms.

.....  
.....  
.....  
.....  
.....

[2]

**37(a).** Semi-conservative replication describes the process by which DNA is replicated in all living organisms.

- i. Explain the meaning of the phrase *semi-conservative replication*.

.....

.....

**[1]**

- ii. DNA ligase is one enzyme involved in the replication of DNA.  
**State two** other enzymes involved and describe their functions.

.....

.....

.....

.....

.....

.....

.....

.....

**[4]**

(b). In 1958, Matthew Meselson and Franklin Stahl carried out an experiment that provided evidence to support the hypothesis of semi-conservative replication of DNA.

Meselson and Stahl grew *E. coli* bacteria in a growth medium that contained only the heavy isotope of nitrogen  $^{15}\text{N}$ . They transferred the bacteria to a growth medium that had the light  $^{14}\text{N}$  isotope and allowed the bacteria to undergo cell division.

After each division, the DNA from some of the bacteria was extracted from the culture and centrifuged to separate it. Fig. 25 shows the bands of DNA in the centrifuge tubes after a specific number of divisions.

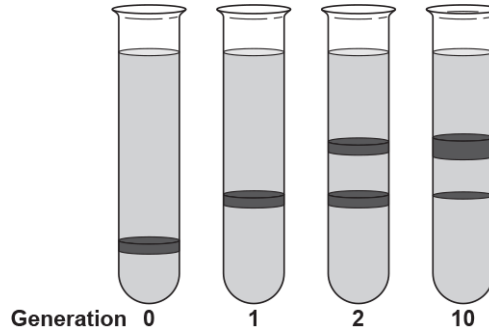

Fig. 25

The tube labelled **Generation 0** in Fig. 25 shows a single band of DNA containing bases that contain only the heavy isotope of nitrogen  $^{15}\text{N}$ .

Explain how the results from the other generations provide evidence to support the hypothesis that DNA replication is semi-conservative.

.....

.....

.....

.....

.....

[2]

38.

i. Outline how the process of DNA replication is completed, following the pairing of nitrogenous bases.

.....

.....

.....

.....

.....

[3]

ii. Why is DNA replication described as semi-conservative?

.....  
.....

[1]

**39.** Pepsin is a protease enzyme with a polypeptide chain containing 327 amino acids.

Titin is the largest known protein. It has a polypeptide chain containing at least 92 times more amino acids than pepsin.

i. DNA sequences in genes code for polypeptide molecules such as pepsin and titin.

Explain why a process known as transcription is necessary for polypeptide synthesis.

.....  
.....  
.....  
.....

[2]

ii. Calculate the minimum length of the DNA base sequence required to code for titin.

Show your working.

Answer ..... [2]



iii. \* Titin is a fibrous protein. Pepsin is a globular protein.

Compare the properties and functions of fibrous proteins and globular proteins in the human body.

-----

-----

-----

-----

-----

-----

-----

-----

-----

-----

-----

-----

-----

-----

-----

-----

-----

-----

-----

-----

-----

-----

- iv. Another protease enzyme is HIV1 protease, which is essential for the life cycle of the human immunodeficiency virus (HIV). Inhibition of this protease prevents HIV from maturing.

In 1995, saquinavir was the first HIV1 protease inhibitor drug to be approved by the US Food and Drug Administration (FDA).

The data in Fig. 1.3 show the number of acquired immune deficiency syndrome (AIDS) diagnoses and deaths between 1981 and 2007 in the US.

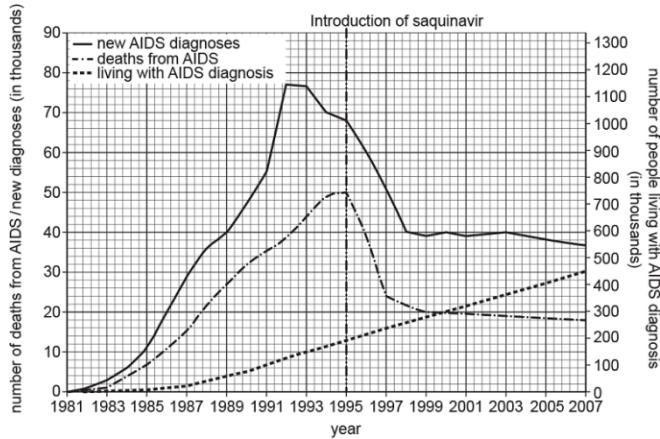

Fig. 1.3

Calculate the rate of decrease in deaths from AIDS between 1995 and 1998.

Give your answer to **two significant figures**.

Show your working.

Answer ..... Units ..... [2]

- v. A student looking at the data in Fig. 1.3 made the following conclusion:

"The decrease in deaths from AIDS after 1995 is because of the use of saquinavir by HIV patients."

Suggest why this conclusion may be invalid based on the data in Fig. 1.3.

.....

.....

.....

.....

.....

[2]

40.

DNA is a polymer of nucleotides that contains the genetic code needed for a protein to be made. Tubulin is a protein that is found in all eukaryotes and some prokaryotes.

i. Explain how the genetic code in the gene for tubulin codes for the protein tubulin.

-----  
-----  
-----  
-----  
-----

[2]

ii. Tubulin is a globular protein that can polymerise to form the cell cytoskeleton.

One example of this is the formation of microtubules, which form the spindle fibres to move chromatids during mitosis and meiosis.

Describe **three** other cellular functions of the cytoskeleton.

-----  
-----  
-----  
-----  
-----  
-----  
-----  
-----  
-----

[3]

iii. Suggest **two** ways tubulin is essential to protein synthesis and protein secretion in eukaryotic cells.

1

-----

2

-----

-----

[2]

41. Which of the following statements, **A** to **D**, about the nature of the genetic code is **incorrect**?

- A. It is a degenerate code.
- B. It is a triplet code.
- C. It is overlapping.
- D. It is universal.

Your answer

[1]